



GB-SS SERIES

Single stage & Single driven

Gas Booster GB-SS consists of single stage and single driven part.
There are **5 types depending on compression ratio.**
(compression ratio: 1:7 / 14 / 30 / 50 / 75)

GB-SS SPECIFICATION

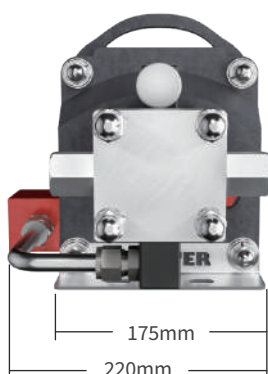
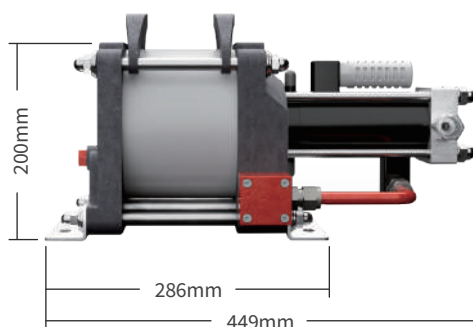

※ Please contact sales staff if you need further assistance.

Model	SS - 7	SS - 14	SS - 30	SS - 50	SS - 75
Ratio	1 : 7	1 : 14	1 : 30	1 : 50	1 : 75
Air Drive Pressure (kg / cm ²)	5 ~ 10				
Max. Pressure (kg / cm ²)	49	98	210	350	525
Min.Suction Pressure (kg / cm ²)	4	7	14	21	35
Connections (inlet / outlet)	1/2" PT / 1/2" PT		9/16" 18 UNF / 9/16" 18 UNF		
Weight (kg)	16	16	17	18	18

※ M.P(kg/cm²) = Ratio * Air Drive Pressure(kg/cm²) ※ M.P is calculated with 7 bar(standardized air pressure).

※ Weight is approximate value.

GB-SS PERFORMANCE CURVES

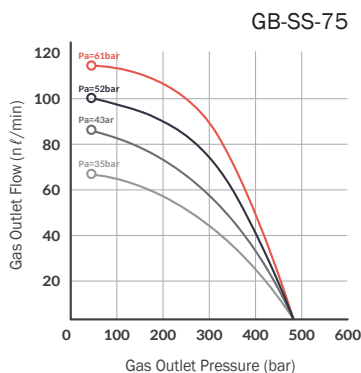
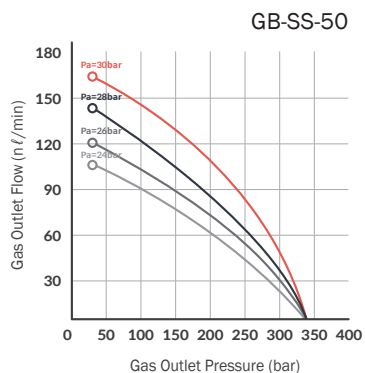
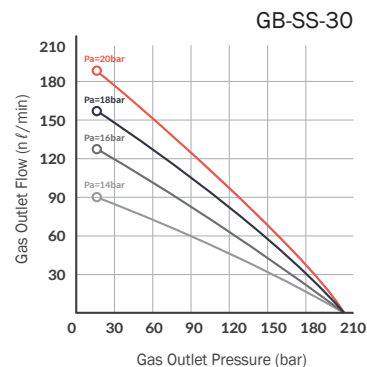
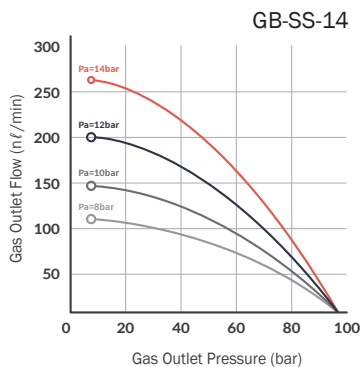
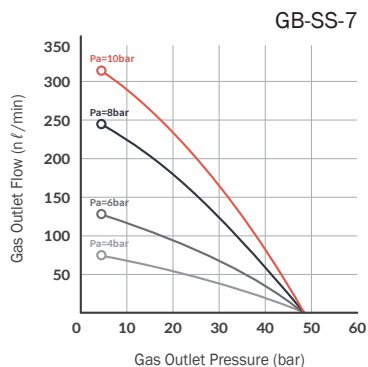

Theoretical charging time formula

Reservoir tank x atm = TAL

TAL / (Flow rate/sec) = total charging time

* Outlet pressure (Pb) = IPI

(Outlet Pressure = Compression ratio · Air drive)

Precautions

- There are lots of variables when increasing pressure under high pressure.
- Driven part: driven air pressure, flow rate
- High pressure part: inflow gas pressure, feed rate
- Actual flow rate will be different depending on utility.

GB-SS OVERVIEW

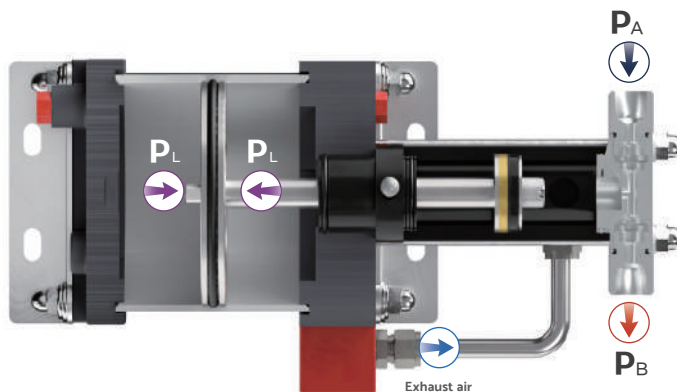

P_A Suction gas

P_B Discharging gas

P_L Air drive